

ID 800H2

(8 mm)

Freno Idraulico ad Azionamento Diretto - Positivo

Direct Hydraulic Brake - Oil Applied

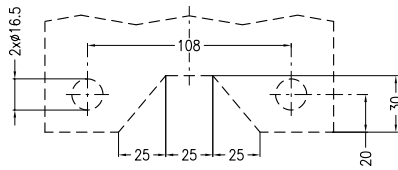

Dimensioni base di montaggio
Dimensions of mounting base

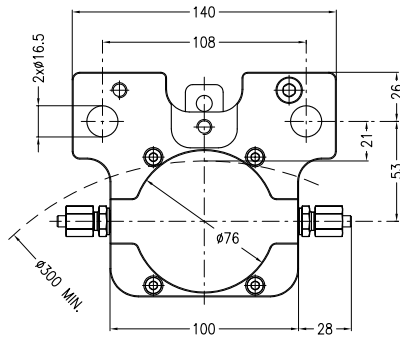

Montaggio laterale
Side Mounting

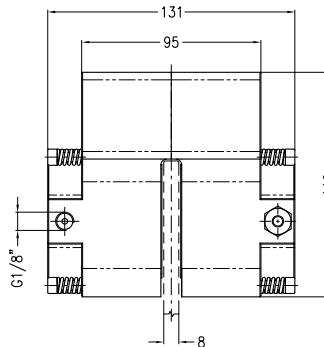

Ingombro estrazione ferodi
Space required for pads removal

Montaggio con piastra centrale (*)
Mounting with central plate (*)

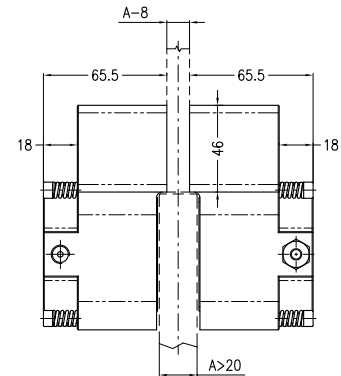

(*) Per uso con dischi spessore maggiore di 20 mm le due pinze possono essere montate usando una piastra centrale di spessore = sp. disco - 8 mm.
(*) For use with discs thickness greater than 20 mm the two calipers could be mounted using a central plate of thickness = disc th. - 8 mm.

Dati Coppia / Torque data

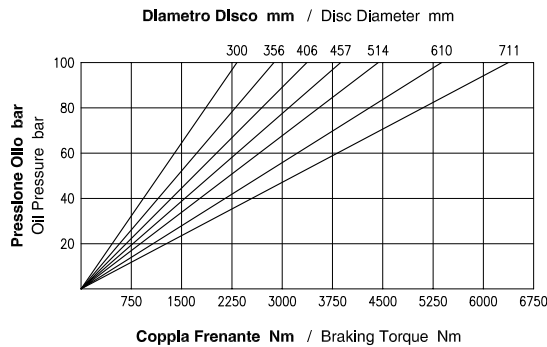

Attenzione: La coppia iniziale può essere inferiore dal 30% al 50% rispetto al valore nominale. **Warning:** The initial braking torque can be from 30% to 50% lower than the nominal value.

Dati Forza / Force data

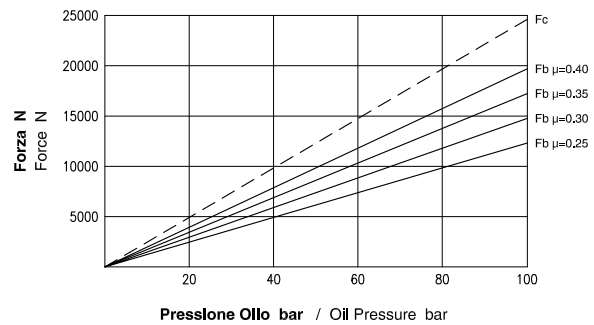

NOTA: Il grafico riporta l'andamento della forza tangenziale al variare del coefficiente di attrito. **NOTE:** The diagram shows the braking force performance with different friction coefficients.

Dati Tecnici

Coefficiente di attrito nominale $\mu = 0.40$
Forza tangenziale $F_b = F_c \cdot 2 \cdot \mu$ (N)

Forza di chiusura $F_c : 24625$ N a 100 bar
Forza tangenziale $F_b : 19700$ N a 100 bar

Raggio effettivo disco $R_e =$ Raggio disco (m) - 0.032
Coppia frenante $M_b = F_b \cdot R_e$ (Nm)

Pressione Min. : 3.3 bar
Pressione Max : 110 bar
Volume olio : 0.06 dm³
Volume olio per uno spostamento di 2mm per ciascun ferodo : 0.01 dm³

Peso : 8.2 kg
Spessore del ferodo nuovo : 7.5 mm
Usura Max totale : 10 mm

Technical Data

Nominal friction coefficient $\mu = 0.40$
Braking force $F_b = F_c \cdot 2 \cdot \mu$ (N)

Clamping force $F_c : 24625$ N at 100 bar
Braking force $F_b : 19700$ N at 100 bar

Effective disc radius $R_e =$ Disc radius (m) - 0.032
Braking torque $M_b = F_b \cdot R_e$ (Nm)

Min. pressure : 3.3 bar
Max pressure : 110 bar
Oil volume : 0.06 dm³
Total oil displacement for 2mm movement of each pad : 0.01 dm³

Weight : 8.2 kg
Thickness of new lining : 7.5 mm
Max total wear : 10 mm



Coremo Ocmea S.p.A. - T +39 02 4880697 - F +39 02 4881940
E-mail : info@coremo.it - Internet : www.coremo.com

I.T. 190201