

# A3ID

## Freno Idraulico a Pinza - Positivo Hydraulic Caliper Brake - Oil applied

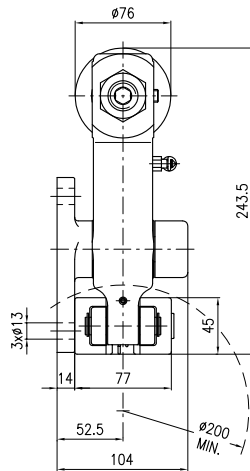

A	B	C	C1 (max)
Spessore Disco Disc Thickness			
mm	mm	mm	mm
12.7	73	153.5	176
25.4	86	160	182.5

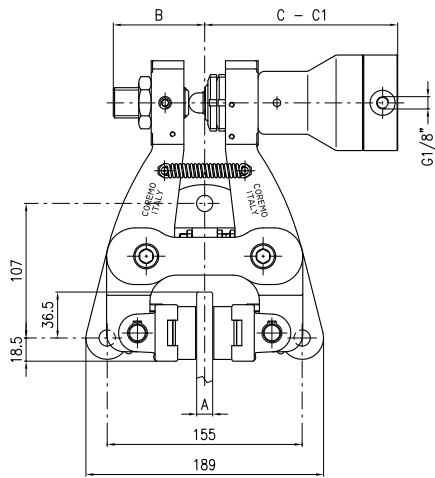
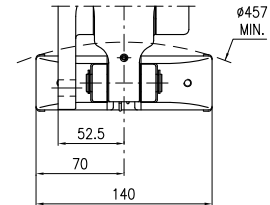

**Versione Pattino Doppio**  
Double Pad Version

### Dati Coppia / Torque data

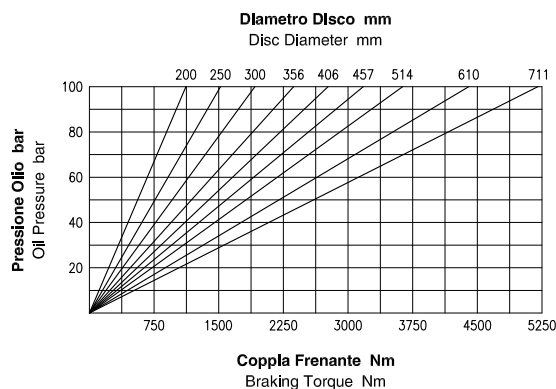

**Attenzione:** La coppia iniziale può essere inferiore dal 30% al 50% rispetto al valore nominale. **Warning:** The initial braking torque can be from 30% to 50% lower than the nominal value.

### Dati Forza / Force data

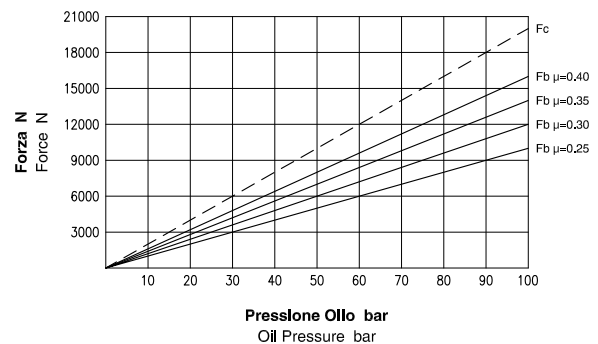

**NOTA:** Il grafico riporta l'andamento della forza tangenziale al variare del coefficiente di attrito. **NOTE:** The diagram shows the braking force performance with different friction coefficients.

### Dati Tecnici

Coefficiente di attrito nominale  $\mu = 0.40$

Forza tangenziale  $F_b = F_c \cdot 2 \cdot \mu$  (N)

Forza di chiusura  $F_c$  : 20000 N a 100 bar

Forza tangenziale  $F_b$  : 16000 N a 100 bar

Raggio effettivo disco  $R_e =$  Raggio disco (m) - 0.03

Coppia frenante  $M_b = F_b \cdot R_e$  (Nm)

Pressione Max : 100 bar

Volume olio : 0.025 dm<sup>3</sup>

Volume olio per uno spostamento di 2mm per ciascun ferodo : 0.009 dm<sup>3</sup>

Peso versione standard : 12.6 kg

Peso versione pattino doppio : 13.3 kg

Spessore del ferodo nuovo : 16 mm

Usura Max totale : 16 mm

### Technical Data

Nominal friction coefficient  $\mu = 0.40$

Braking force  $F_b = F_c \cdot 2 \cdot \mu$  (N)

Clamping force  $F_c$  : 20000 N at 100 bar

Braking force  $F_b$  : 16000 N at 100 bar

Effective disc radius  $R_e =$  Disc radius (m) - 0.03

Braking torque  $M_b = F_b \cdot R_e$  (Nm)

Max pressure : 100 bar

Oil Volume : 0.025 dm<sup>3</sup>

Total oil displacement for 2mm movement of each pad : 0.009 dm<sup>3</sup>

Weight standard version : 12.6 kg

Weight double pad version : 13.3 kg

Thickness of new lining : 16 mm

Max total wear : 16 mm



Coremo Ocmea S.p.A. - T +39 02 4880697 - F +39 02 4881940

E-mail : info@coremo.it - Internet : www.coremo.com

I.T. 181205