

GL3

Freno Pneumatico a Pinza - Positivo Pneumatic Caliper Brake - Air applied

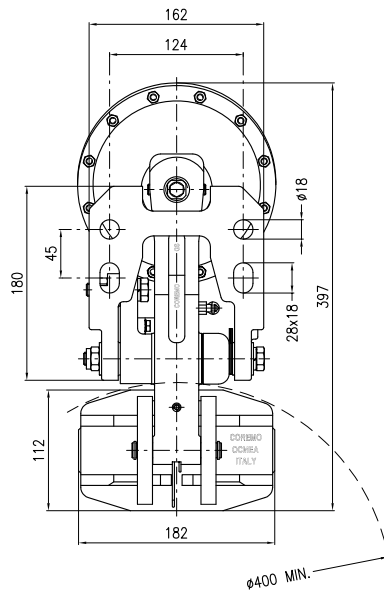

Dati Coppia / Torque data

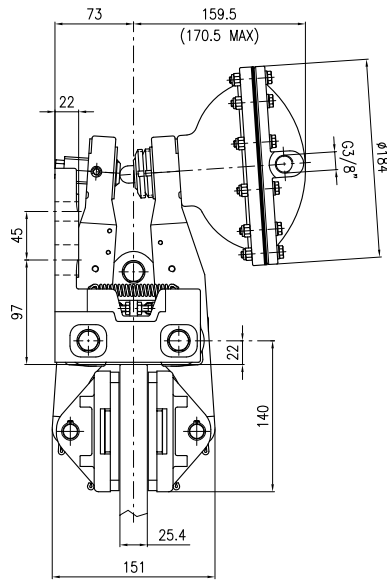
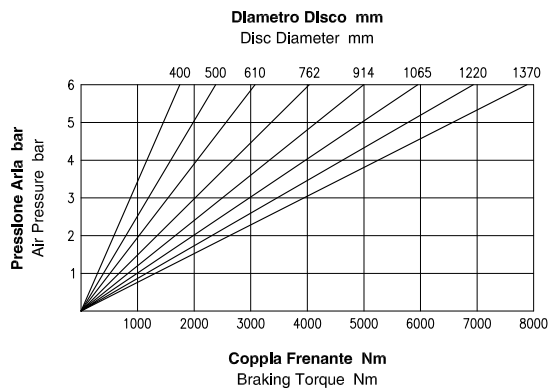

Attenzione: La coppia iniziale può essere inferiore dal 30% al 50% rispetto al valore nominale. **Warning:** The initial braking torque can be from 30% to 50% lower than the nominal value.

Dati Forza / Force data

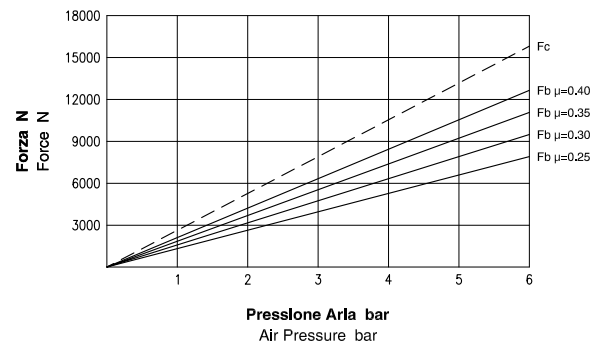

NOTA: Il grafico riporta l'andamento della forza tangenziale al variare del coefficiente di attrito. **NOTE:** The diagram shows the braking force performance with different friction coefficients.

Dati Tecnici

Coefficiente di attrito nominale $\mu = 0.40$
Forza tangenziale $F_b = F_c \cdot 2 \cdot \mu$ (N)

Forza di chiusura F_c : 15812.5 N a 6 bar
Forza tangenziale F_b : 12650 N a 6 bar

Raggio effettivo disco $R_e =$ Raggio disco (m) - 0.062
Coppia frenante $M_b = F_b \cdot R_e$ (Nm)

Pressione Max : 6 bar
Volume aria : 0.45 dm³

Peso : 21.6 kg

Spessore del ferodo nuovo : 8 mm
Usura Max totale : 10 mm

Technical Data

Nominal friction coefficient $\mu = 0.40$
Braking force $F_b = F_c \cdot 2 \cdot \mu$ (N)

Clamping force F_c : 15812.5 N at 6 bar
Braking force F_b : 12650 N at 6 bar

Effective disc radius $R_e =$ Disc radius (m) - 0.062
Braking torque $M_b = F_b \cdot R_e$ (Nm)

Max pressure : 6 bar
Air Volume : 0.45 dm³

Weight : 21.6 kg

Thickness of new lining : 8 mm
Max total wear : 10 mm



Coremo Ocea S.p.A. - T +39 02 4880697 - F +39 02 4881940

E-mail : info@coremo.it - Internet : www.coremo.com

I.T. 201019