

G1

Freno Pneumatico a Pinza - Positivo

Pneumatic Caliper Brake - Air applied

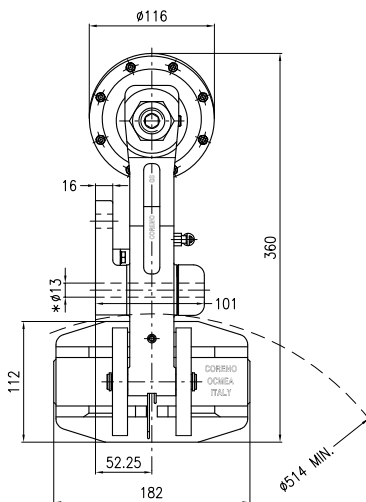
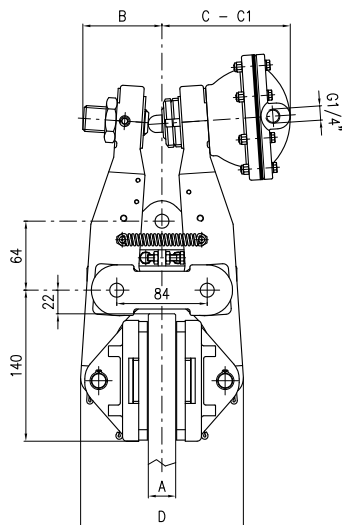

A	B	C	C1 (max)	D
Spessore Disco Disc Thickness mm	mm	mm	mm	mm
25.4	73.5	119	130	151
40	85.5	127	138	165.5

Applicable anche su disco spessore 30 mm
Applicable also on disc thickness 30 mm

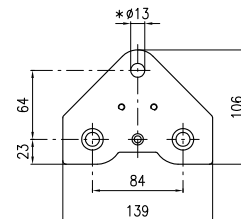

Vista Base di Montaggio
Mounting Base View

- * Viti M12 classe 8.8 fornite con la pinza
- * Bolts M12 grade 8.8 supplied with caliper

Dati Coppia / Torque data

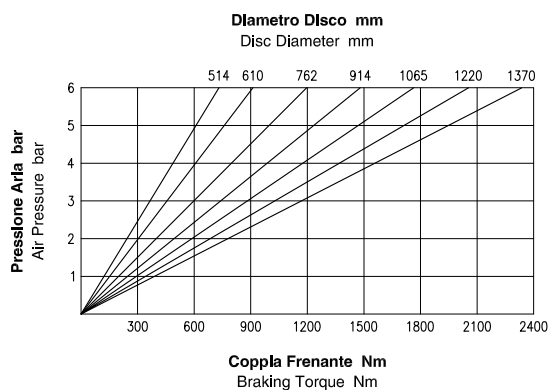

Attenzione: La coppia iniziale può essere inferiore dal 30% al 50% rispetto al valore nominale. **Warning:** The initial braking torque can be from 30% to 50% lower than the nominal value.

Dati Forza / Force data



NOTA: Il grafico riporta l'andamento della forza tangenziale al variare del coefficiente di attrito. **NOTE:** The diagram shows the braking force performance with different friction coefficients.

Dati Tecnici

Coefficiente di attrito nominale $\mu = 0.40$
Forza tangenziale $F_b = F_c \cdot 2 \cdot \mu$ (N)
Forza di chiusura $F_c : 4687.5$ N a 6 bar
Forza tangenziale $F_b : 3750$ N a 6 bar
Raggio effettivo disco $R_e =$ Raggio disco (m) - 0.062
Coppia frenante $M_b = F_b \cdot R_e$ (Nm)
Pressione Max : 6 bar
Volume aria : 0.1 dm³
Peso : 15.7 kg
Spessore del ferodo nuovo : 8 mm
Usura Max totale : 10 mm

Technical Data

Nominal friction coefficient $\mu = 0.40$
Braking force $F_b = F_c \cdot 2 \cdot \mu$ (N)
Clamping force $F_c : 4687.5$ N at 6 bar
Braking force $F_b : 3750$ N at 6 bar
Effective disc radius $R_e =$ Disc radius (m) - 0.062
Braking torque $M_b = F_b \cdot R_e$ (Nm)
Max pressure : 6 bar
Air Volume : 0.1 dm³
Weight : 15.7 kg
Thickness of new lining : 8 mm
Max total wear : 10 mm



Coremo Ocmea S.p.A. - T +39 02 4880697 - F +39 02 4881940
 E-mail : info@coremo.it - Internet : www.coremo.com

I.T. 170201