

A3NID

Freno Idraulico a Pinza - Negativo Hydraulic Caliper Brake - Spring applied

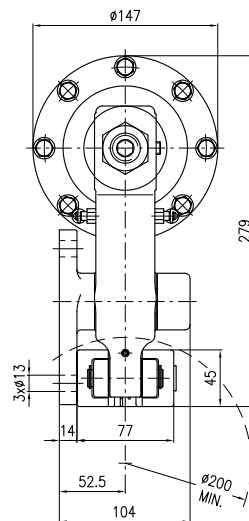

A Spessore Disco Disc Thickness mm	B mm	C mm	C1 (max) mm
12.7	72.5	234.5	259
25.4	86	241	265.5

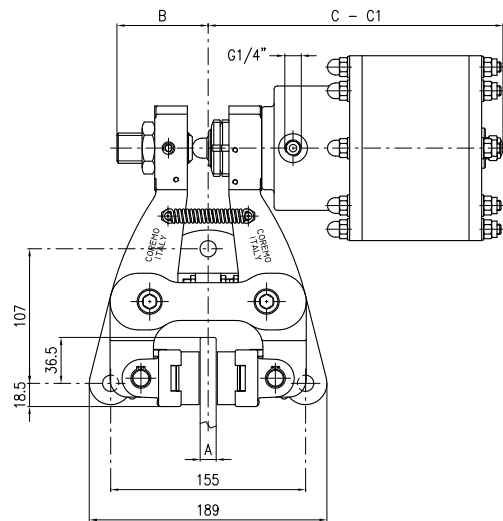
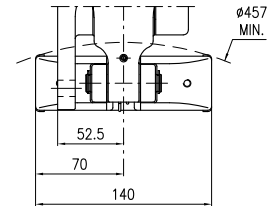

Versione Pattino Doppio
Double Pad Version

Dati Coppia / Torque data

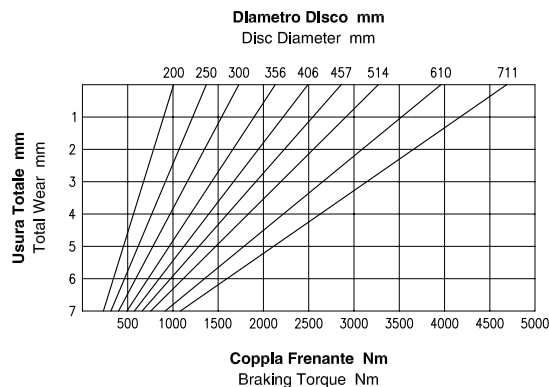

Attenzione: La coppia iniziale può essere inferiore dal 30% al 50% rispetto al valore nominale. **Warning:** The initial braking torque can be from 30% to 50% lower than the nominal value.

Dati Forza / Force data

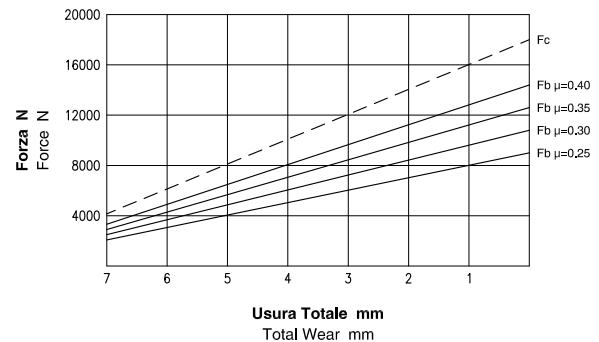

NOTA: Il grafico riporta l'andamento della forza tangenziale al variare del coefficiente di attrito. **NOTE:** The diagram shows the braking force performance with different friction coefficients.

Dati Tecnici

Coefficiente di attrito nominale $\mu = 0.40$
Forza tangenziale $F_b = F_c \cdot 2 \cdot \mu$ (N)

Forza di chiusura F_c : 18000 N
Forza tangenziale F_b : 14400 N

Raggio effettivo disco $R_e = \text{Raggio disco (m)} - 0.03$
Coppia frenante $M_b = F_b \cdot R_e$ (Nm)

Pressione minima di apertura : 50 bar
Pressione Max : 100 bar

Volume olio : 0.08 dm³
Volume olio per uno spostamento di 2mm per ciascun ferodo : 0.018 dm³

Peso versione standard : 17.5 kg
Peso versione pattino doppio : 18.2 kg

Spessore del ferodo nuovo : 16 mm
Usura Max totale : 16 mm

Technical Data

Nominal friction coefficient $\mu = 0.40$
Braking force $F_b = F_c \cdot 2 \cdot \mu$ (N)

Clamping force F_c : 18000 N
Braking force F_b : 14400 N

Effective disc radius $R_e = \text{Disc radius (m)} - 0.03$
Braking torque $M_b = F_b \cdot R_e$ (Nm)

Minimum release pressure : 50 bar
Max pressure : 100 bar

Oil Volume : 0.08 dm³
Total oil displacement for 2mm movement of each pad : 0.018 dm³

Weight standard version : 17.5 kg
Weight double pad version : 18.2 kg

Thickness of new lining : 16 mm
Max total wear : 16 mm



Coremo Ocomea S.p.A. - T +39 02 4880697 - F +39 02 4881940

E-mail : info@coremo.it - Internet : www.coremo.com

I.T. 181130