

D05

Freno Pneumatico a Pinza - Positivo

Pneumatic Caliper Brake - Air applied

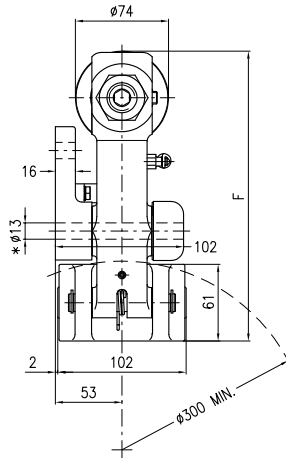
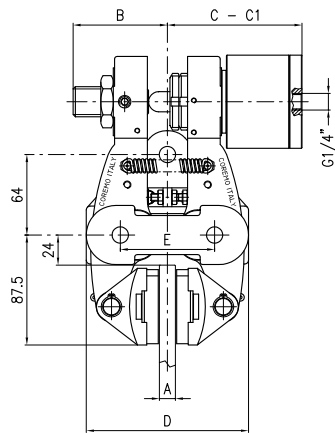

A	B	C	C1 (max)	D	E	F
Spessore Disco Disc Thickness mm	mm	mm	mm	mm	mm	mm
12.7	75	107	124	129	75	230.5
25.4	74.5	109	124	132	84	232.5
30	86	116	133.5	140	75	230.5
40	81.5	120.5	137	149	84	230.5

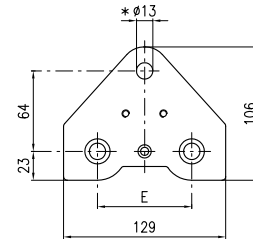

Vista Base di Montaggio
Mounting Base View

- * Viti M12 classe 8.8 fornite con la pinza
- * Bolts M12 grade 8.8 supplied with caliper

Dati Coppia / Torque data

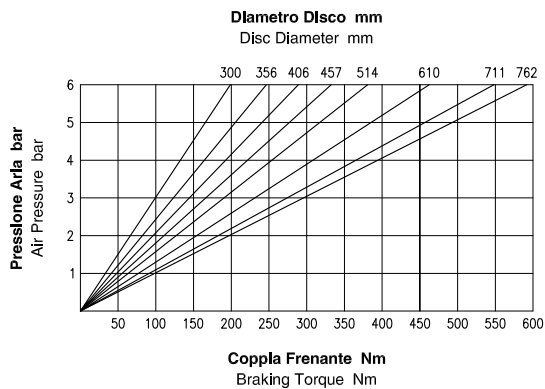

Attenzione: La coppia iniziale può essere inferiore dal 30% al 50% rispetto al valore nominale. **Warning:** The initial braking torque can be from 30% to 50% lower than the nominal value.

Dati Forza / Force data

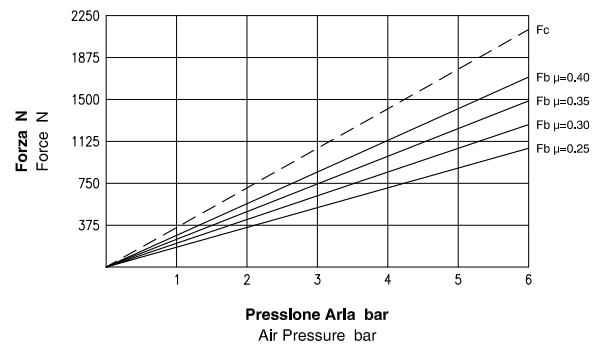

NOTA: Il grafico riporta l'andamento della forza tangenziale al variare del coefficiente di attrito. **NOTE:** The diagram shows the braking force performance with different friction coefficients.

Dati Tecnici

Coefficiente di attrito nominale $\mu = 0.40$
Forza tangenziale $F_b = F_c \cdot 2 \cdot \mu$ (N)

Forza di chiusura F_c : 2125 N a 6 bar
Forza tangenziale F_b : 1700 N a 6 bar

Raggio effettivo disco $R_e =$ Raggio disco (m) - 0.033
Coppia frenante $M_b = F_b \cdot R_e$ (Nm)

Pressione Max : 6 bar
Volume aria : 0.05 dm³

Peso : 9.5 kg

Spessore del ferodo nuovo : 12 mm
Usura Max totale : 11 mm

Technical Data

Nominal friction coefficient $\mu = 0.40$
Braking force $F_b = F_c \cdot 2 \cdot \mu$ (N)

Clamping force F_c : 2125 N at 6 bar
Braking force F_b : 1700 N at 6 bar

Effective disc radius $R_e =$ Disc radius (m) - 0.033
Braking torque $M_b = F_b \cdot R_e$ (Nm)

Max pressure : 6 bar
Air Volume : 0.05 dm³

Weight : 9.5 kg

Thickness of new lining : 12 mm
Max total wear : 11 mm



Coremo Ocmea S.p.A. - T +39 02 4880697 - F +39 02 4881940
E-mail : info@coremo.it - Internet : www.coremo.com

I.T. 170201