

F2

Freno Pneumatico a Pinza - Positivo Pneumatic Caliper Brake - Air applied

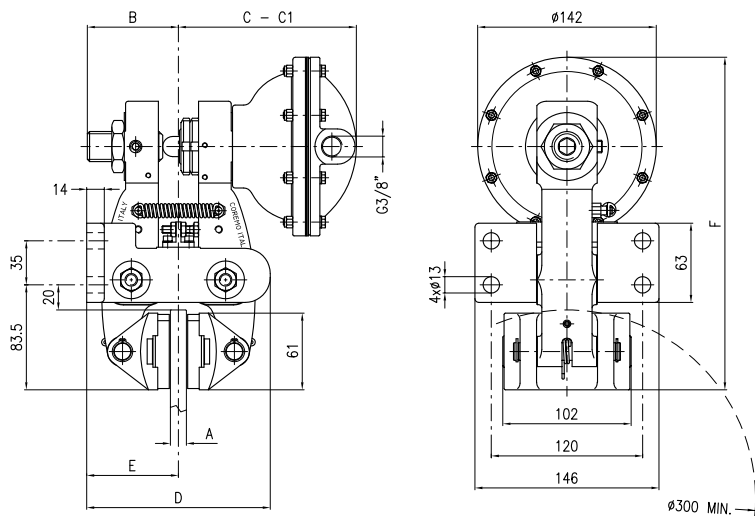

| A | B | C | C1 (max) | D | E | F |
|----------------------------------------|------|-------|----------|-----|------|-------|
| Spessore Disco Disc Thickness mm | mm | mm | mm | mm | mm | mm |
| 12.7 | 72.5 | 141.5 | 154 | 146 | 73 | 264.5 |
| 25.4 | 72 | 142 | 155.5 | 146 | 77.5 | 267.5 |
| 30 | 83.5 | 150.5 | 163.5 | 146 | 73 | 264.5 |
| 40 | 79 | 155 | 167 | 152 | 77.5 | 264.5 |

Dati Coppia / Torque data

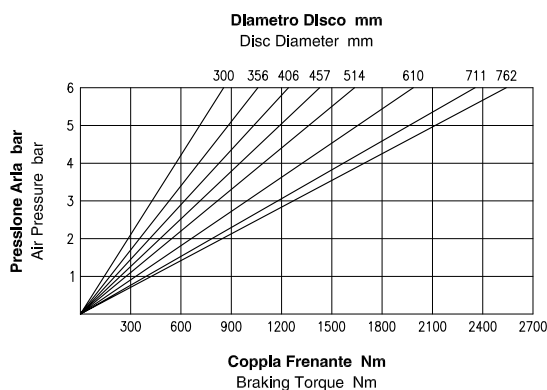

Attenzione: La coppia iniziale può essere inferiore dal 30% al 50% rispetto al valore nominale. **Warning:** The initial braking torque can be from 30% to 50% lower than the nominal value.

Dati Forza / Force data

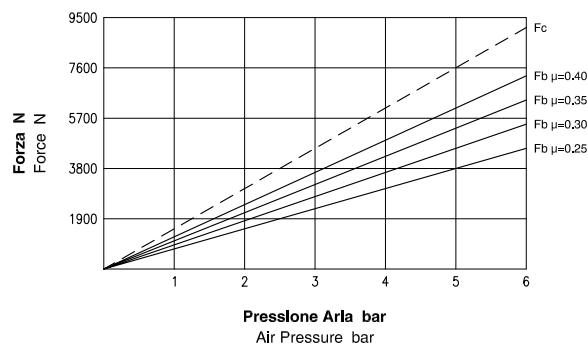

NOTA: Il grafico riporta l'andamento della forza tangenziale al variare del coefficiente di attrito. **NOTE:** The diagram shows the braking force performance with different friction coefficients.

Dati Tecnici

Coefficiente di attrito nominale $\mu = 0.40$
Forza tangenziale $F_b = F_c \cdot 2 \cdot \mu$ (N)
Forza di chiusura $F_c : 9125$ N a 6 bar
Forza tangenziale $F_b : 7300$ N a 6 bar
Raggio effettivo disco $R_e =$ Raggio disco (m) - 0.033
Coppia frenante $M_b = F_b \cdot R_e$ (Nm)
Pressione Max : 6 bar
Volume aria : 0.2 dm³
Peso : 10.3 kg
Spessore del ferodo nuovo : 12 mm
Usura Max totale : 11 mm

Technical Data

Nominal friction coefficient $\mu = 0.40$
Braking force $F_b = F_c \cdot 2 \cdot \mu$ (N)
Clamping force $F_c : 9125$ N at 6 bar
Braking force $F_b : 7300$ N at 6 bar
Effective disc radius $R_e =$ Disc radius (m) - 0.033
Braking torque $M_b = F_b \cdot R_e$ (Nm)
Max pressure : 6 bar
Air Volume : 0.2 dm³
Weight : 10.3 kg
Thickness of new lining : 12 mm
Max total wear : 11 mm



Coremo Ocmea S.p.A. - T +39 02 4880697 - F +39 02 4881940
 E-mail : info@coremo.it - Internet : www.coremo.com

I.T. 170201