

G3NID-17

Freno Idraulico a Pinza - Negativo Hydraulic Caliper Brake - Spring applied

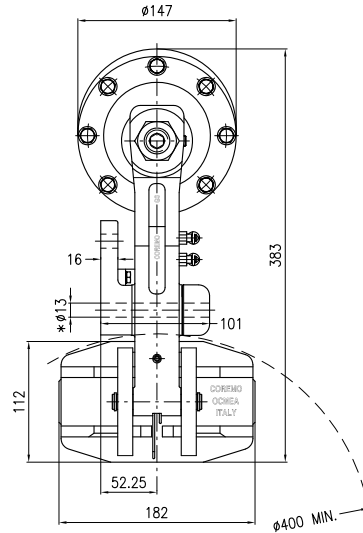
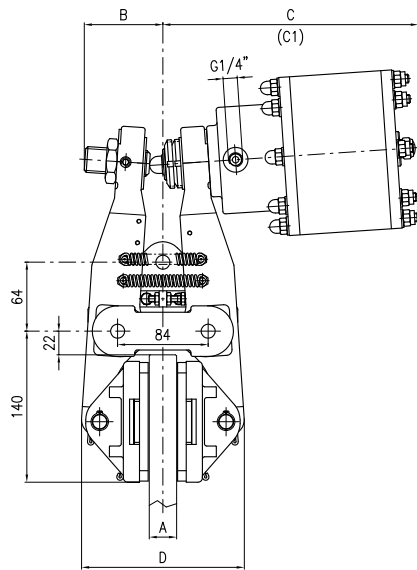

A	B	C	C1 (max)	D
Spessore Disco Disc Thickness				
mm	mm	mm	mm	mm
25.4	73	237	245.5	151
40	85.5	245	253.5	165.5

Applicable anche su disco spessore 30 mm
Applicable also on disc thickness 30 mm

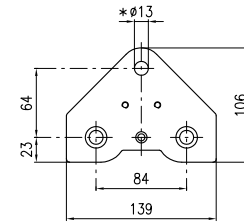

Vista Base di Montaggio
Mounting Base View

- * Viti M12 classe 8.8 fornite con la pinza
- * Bolts M12 grade 8.8 supplied with caliper

Dati Coppia / Torque data

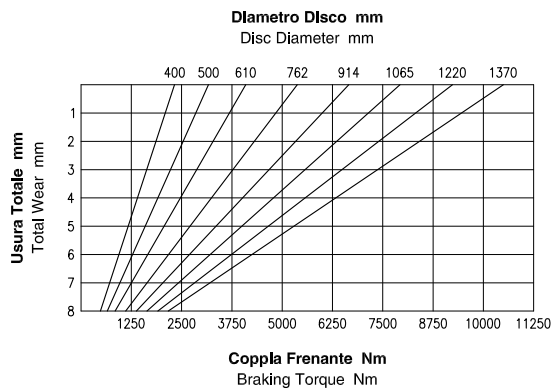

Attenzione: La coppia iniziale può essere inferiore dal 30% al 50% rispetto al valore nominale. **Warning:** The initial braking torque can be from 30% to 50% lower than the nominal value.

Dati Forza / Force data

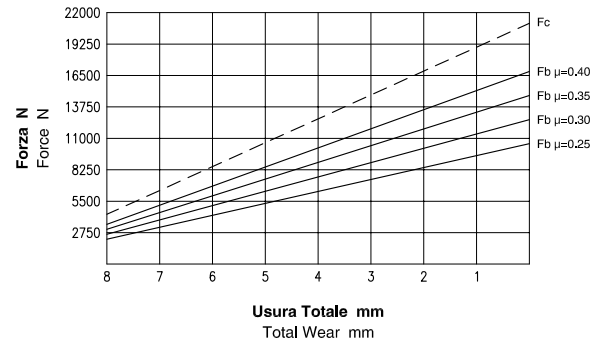

NOTA: Il grafico riporta l'andamento della forza tangenziale al variare del coefficiente di attrito. **NOTE:** The diagram shows the braking force performance with different friction coefficients.

Dati Tecnici

Coefficiente di attrito nominale $\mu = 0.40$
Forza tangenziale $F_b = F_c \cdot 2 \cdot \mu$ (N)
Forza di chiusura $F_c : 21062.5$ N
Forza tangenziale $F_b : 16850$ N
Raggio effettivo disco $R_e =$ Raggio disco (m) - 0.062
Coppia frenante $M_b = F_b \cdot R_e$ (Nm)
Pressione minima di apertura : 70 bar
Pressione Max : 100 bar
Volume olio : 0.08 dm³
Volume olio per uno spostamento di 2mm per ciascun ferodo : 0.017 dm³
Peso : 22.4 kg
Spessore del ferodo nuovo : 8 mm
Usura Max totale : 10 mm

Technical Data

Nominal friction coefficient $\mu = 0.40$
 Braking force $F_b = F_c \cdot 2 \cdot \mu$ (N)
 Clamping force $F_c : 21062.5$ N
 Braking force $F_b : 16850$ N
 Effective disc radius $R_e =$ Disc radius (m) - 0.062
 Braking torque $M_b = F_b \cdot R_e$ (Nm)
 Minimum release pressure : 70 bar
 Max pressure : 100 bar
 Oil Volume : 0.08 dm³
 Total oil displacement for 2mm movement of each pad : 0.017 dm³
 Weight : 22.4 kg
 Thickness of new lining : 8 mm
 Max total wear : 10 mm



Coremo Ocmea S.p.A. - T +39 02 4880697 - F +39 02 4881940
 E-mail : info@coremo.it - Internet : www.coremo.com

I.T. 210618